



# WASHING

## HIGH SPIN WASHERS LOW AND MEDIUM CAPACITY FWH-80C TP2



### FEATURES

#### Touch Plus Control

- 7" touchscreen, user friendly and totally programmable .
- Videos on display, ads, instructions.
- Free software for programming, telemetry, data analysis.
- USB Connection.
- 37 languages.
- 8 dosing signals as standard.

#### G FACTOR

- High Spin Up to 500 G Force

#### EFFICIENCY

- Energy Optimization.
- Optimal load.
- KRS: Water Recovery tank ready.
- Low water consumption.

#### VERSATILITY

- Custom - Make to order
- OPL or COIN.
- Electric or Hot water.
- Drain valve or Pump.
- Wet cleaning features.

#### CONNECTIVITY

- IoT - Fagor-Konnect standard.
- Remote technical service.
- Laundry Management system: OPL and COIN.

#### ERGONOMICS

- Large Loading Doors: Ø560.
- Easy opening/closing system for door lock.

#### MAINTENANCE

- Hinged panel: easy and ergonomic access.
  - Technical setting: telemetry, error diagnosis, monitoring, software updates.
- Easy maintenance with external console (optional)

### OTHERS

- Grey skin plate outer casing.
- Drum in stainless steel AISI 304.
- Detergent dispenser with 4 compartments.
- CB and WRAS approved product.
- High spin washers with suspended drum.

### OPTIONS

- Extra dosing pump DB-1.
- Double drain.
- Levelling feet.
- Automatic weighing sensor system on feet.
- Relay card with 6 extra dosing signals.
- Reversible door opening.
- Tropicalized coating.
- Steam kit to transform an E or HW heated machine into steam version.
- Plinth to align loading height (door base at 33.46 In).
- Stainless steel AISI 304 outer casing.
- Stainless steel AISI 304 front panel FWH-80C.
- Coin/token kit.
- Auto unlock kit for the door.

DRUM		U.	FWH - 80C TP2	
Load capacity 1:9 / 1:10		Lb.	86/77.2	
Volume		CU.FT	12.44	
Diameter		In	33.9	
Depth		In	23.7	
GENERAL DETAILS				
Washing speed / Spinning speed		r.p.m.	42.5/966	
G Factor		-	450	
Maximum force transmitted		KN	7.36 ±2.45	
Frequency-dynamic force		Hz	14,3	
Noise level		dB	<70	
Coin laundry version		-	No	
Double drain		-	Opt.	
Weighing System / Tilting System		-	Opt./No	
SLUICE option		-	No	
DOOR				
Height center door / Height door		In	34.9/21.3	
Diameter		In	22.1	
POWER				
Motor		Hp	8	
Electric heating power		kW	21	
Total electric power (electric model)		kW	22	
Total electric power (hw, steam model)		kW	6	
CONNECTIONS		ELECTRIC		STEAM / HOT WATER
Voltage 208-240/60/1~ + G	N° x AWG / A	-		-
Voltage 208-240/60/3~ + G	N° x AWG / A	4 x 4 / 80A		4 x 10 / 30A
Voltage 440-480/3 ~ + G	N° x AWG / A	4 x 8 / 45A		4 x 14 / 15A
Steam inlet (Steam model)	inch	3/4"		
Maximum steam consumption (Steam model)	lbs/h	18		
Water inlet	inch	3/4"		
Water main pressure	Kg/cm2	2-4		
Maximum water consumption	Gal/h	60*		
Drain	mm/inch	3"		
Drainage capacity	Gal/min	52.8		
DIMENSIONS / PACKING DIMENSIONS				
Net Width / Gross Width		In	43.11/47.5	
Net Depth / Gross Depth		In	46.61/52.4	
Net Height / Gross Height		In	68.11/72.9	
Net weight / Gross weight		Lbs.	1621/1733	
Volume		Ft3	95.4	

\* Programme No. 20, 75% load

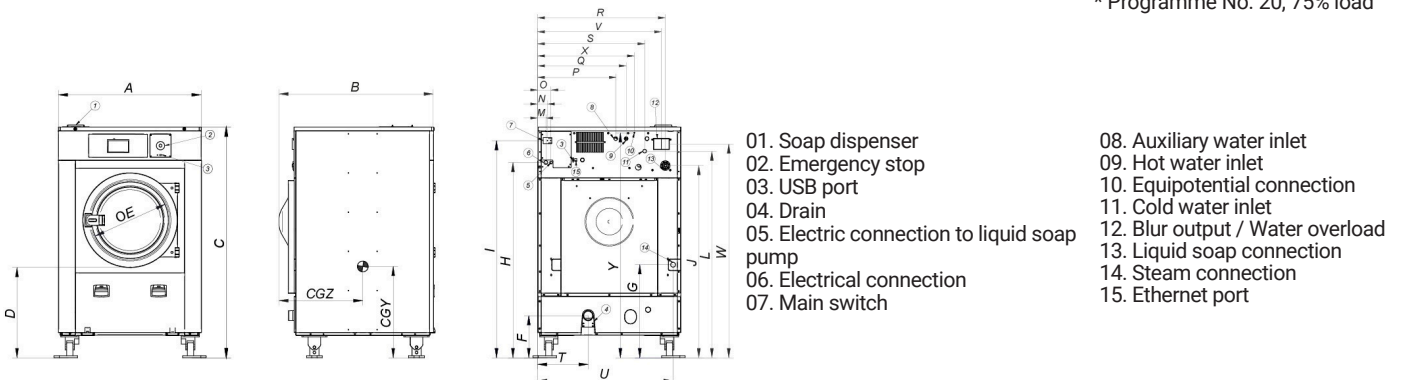

	A	B	C	D	E	F	G	H	I	J	K	L	M	N	O	P	Q	R	S	T	U	V	W	X	Y	CGY	CGZ	
FWH-80C	mm	1095	1184	1730	525	560	158	576	1.330	1498	1331	1513	1417	61	74	101	596	676	976	808	384	1028	946	1496	740	1558	795	732
	In	43.11	46.61	68.11	20.67	22.05	6.22	22.68	52.36	58.98	52.40	59.57	55.78	2.40	2.91	3.98	23.46	26.61	38.43	31.81	15.12	40.47	37.24	58.90	29.13	61.34	31.30	28.82