

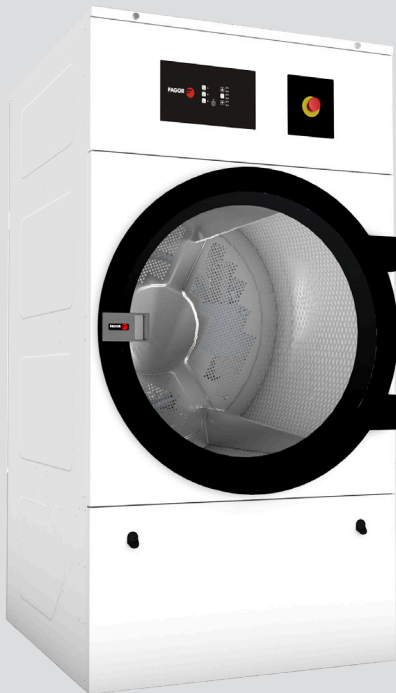

DRYING SINGLE POCKET DRYERS ECONOMIC LINE FED-50 MG



CHARACTERISTICS

M PROGRAMMER

- M programmer: push buttons to control temperature and time.

OUTSTANDING FEATURES

- Reversing drum action is standard.
- Frequency inverter is standard.
- Galvanized drum is standard.

EFFICIENCY

- Big Lint filter.

VERSATILITY

- Make to order - customization.
- OPL > OPL - Standard OPL model easily transformable to coin laundry uses.

ERGONOMICS

- Large Loading Doors.

MAINTENANCE

- Hinged panel: easy and ergonomic access
- Technical menu: statistics for technicians.
- Easy to access to components.

OTHERS

- White painted panels.
- Anti-wrinkle at the end of the cycle.
- Heating options: natural gas and propane.
- CE approved.

OPTIONS

- Opposite door opening.
- Back panel external air + filter.
- M programmer display

SUMMIT
SummitLaundry.com

Call 855-Summit9
Sales@SummitLaundry.com
120 Spagnoli Rd, #1B
Melville, NY 11747

CAPACITY		
	U.	FED-50 MG
Capacity 1/18	Kg	24.3
	Lb	53.9
Capacity 1/20	Kg	22
	Lb	48.5
DRUM		
Ø Drum	mm	835
	inch	32.87
Drum length	mm	800
	inch	31.5
Drum volume	l cu	440
	ft	15.54
Ø Door	mm	574
	inch	22.6
Floor to door center	mm	1030
	inch	40.55
Floor to lower part of the door	mm	672
	inch	26.46
Drum motor power	kW	0.37
ELECTRIC POWER		
Installed heating power	kW	24
Installed electrical power	kW	24.97
Evaporation capacity	l/h	17
	USgallon/h	4.5
Hourly output	Kg/h	34
	Lb/h	75
GAS POWER		
Installed heating power gas	Kcal/h	26655
	Btu/h	105775.6
Installed heating power gas	kW	31
Installed electrical power	kW	0.97
Instant propane gas consumption (G31)	Kg/h	2.66
	Lb/h	5.86
Instant natural gas consumption (G20)	m³/h	3.28
	cfm	1.93
Evaporation capacity	l/h	20
	USgallon/h	5.283
Hourly output Ø Gas inlet	Kg/h	40
	Lb/h	88.2
	BSPP ISO 228-1	1/2"
STEAM POWER		
Installed heating power steam	kW	49.2
	Btu/h	167877
Installed electrical power	kW	0.97
Steam consumption (8 barG) - Stándar	Kg/h	87
Steam consumption (116 psiG)	Lb/h	104.8
Steam pressure - Standard	barG	6 - 9
	psiG	87 - 130.5
Steam inlet - steam outlet - Standard	BSPT- ISO7.1	1"
Steam inlet - condensate outlet	NPT ANSI B1.20.1 Tapered	1"
Steam consumption (5 bagG) - Low pressure	Kg/h	-
Steam consumption (72.5 psiG) - Low pressure	Lb/h	-
Steam pressure - Low Pressure	barG	3 - 6
	psiG	43.5 - 93
Steam Inlet - Steam Outlet - Low Pressure	BSPT - ISO7.1	1"

VENTILATION			
Nominal air flow	m ³ /h	200	
	cfm	706.29	
Air outlet Ø	mm	200	
	inch	8	
Fan motor power	kW	0.55	
HEAT DISSIPATION			
Total max heat dissipation	kW	2.4	
	kW	8193.9	
Front pannel max heat dissipation	Btu/h	1.68	
	Btu/h	5735.8	
CONNECTIONS		ELECTRICAL	GAS
Voltage 120/60/1~ + G	N° x AWG / A	-	3 X 12 / 20 A
Voltage 230V/3~ + G	-	-	-
Voltage 480V/3 ~ + G	-	-	-
DIMENSIONS / PACKING DIMENSIONS			
Net width / Gross width	mm	890 / 970	
	inch	35.04 / 38.19	
Net depth / Gross depth	mm	1255 / 1345	
	inch	49.41 / 52.95	
Net height / Gross height	mm	1812 / 1940	
	inch	71.34 / 76.38	
Net weight / Gross weight	Kg	210 / 230	
	Lb	462.97 / 507.06	
OTHERS			
Sound level	dB	65	

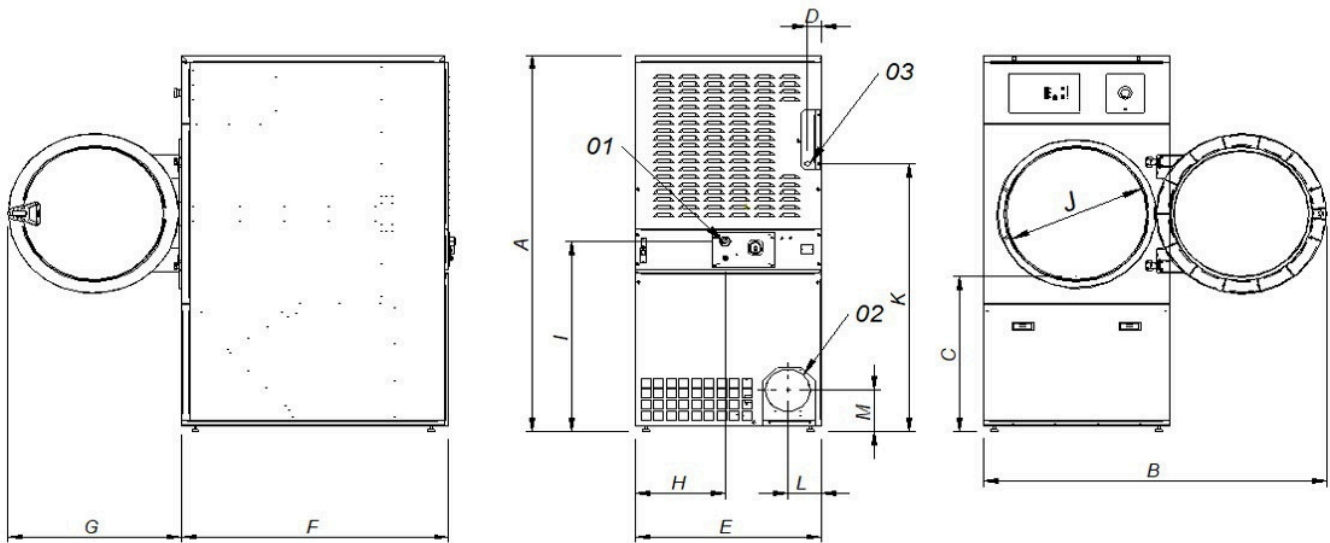

- 01. Power supply
- 02. Fumes output 8"
- 03. Gas inlet 1/2"

	A	B	C	D	E	F	G	H	I	J	K	L	M	N	O
FED-50 MG	71.33	61.10	29.25	4.40	35.03	49.40	28.93	4.21	36.22	22.63	52.91	9.37	7.08	1.45	33.85