

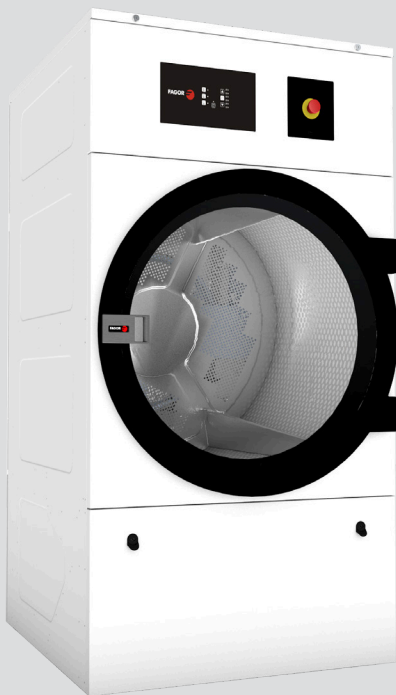

DRYING SINGLE POCKET DRYERS ECONOMIC LINE FED-35 MG



CHARACTERISTICS

M PROGRAMMER

- M programmer: push buttons to control temperature and time.

OUTSTANDING FEATURES

- Reversing drum action is standard.
- Frequency inverter is standard.
- Galvanized drum is standard.

EFFICIENCY

- Big Lint filter.

VERSATILITY

- Make to order - customization.
- OPL > OPL - Standard OPL model easily transformable to coin laundry uses.

ERGONOMICS

- Large Loading Doors.

MAINTENANCE

- Hinged panel: easy and ergonomic access
- Technical menu: statistics for technicians.
- Easy to access to components.

OTHERS

- White painted panels.
- Anti-wrinkle at the end of the cycle.
- Heating options: natural gas and propane.
- CE approved.

OPTIONS

- Opposite door opening.
- Back panel external air + filter.
- M programmer display

CAPACITY		
	U.	FED-35 MG
Capacity 1/18	Kg	18.3
	Lb	40.4
Capacity 1/20	Kg	16.5
	Lb	36.3
DRUM		
Ø Drum	mm	750
	inch	29.53
Drum length	mm	746
	inch	29.37
Drum volume	l cu	330
	ft	11.64
Ø Door	mm	574
	inch	22.6
Floor to door center	mm	976
	inch	38.43
Floor to lower part of the door	mm	618
	inch	24.33
Drum motor power	kW	0.37
ELECTRIC POWER		
Installed heating power	kW	18
Installed electrical power	kW	18.97
Evaporation capacity	l/h	14.10
	USgallon/h	3.72
Hourly output	Kg/h	28.3
	Lb/h	62.4
GAS POWER		
Installed heating power gas	Kcal/h	17638
	Btu/h	70000
Installed heating power gas	kW	20.51
Installed electrical power	kW	0.67
Instant propane gas consumption (G31)	Kg/h	1.76
	Lb/h	3.88
Instant natural gas consumption (G20)	m³/h	2.17
	cfm	1.28
Evaporation capacity	l/h	16.3
	USgallon/h	4.306
Hourly output Ø Gas inlet	Kg/h	31.9
	Lb/h	70.3
	BSPP ISO 228-1	1/2"
STEAM POWER		
Installed heating power steam	kW	30
	Btu/h	102364
Installed electrical power	kW	0.67
Steam consumption (8 barG) - Stándar	Kg/h	53
Steam consumption (116 psiG)	Lb/h	63.8
Steam pressure - Standard	barG	6 - 9
	psiG	87 - 130.5
Steam inlet - steam outlet - Standard	BSPT- ISO7.1	3/4"
Steam inlet - condensate outlet	NPT ANSI B1.20.1 Tapered	3/4"
Steam consumption (5 bagG) - Low pressure	Kg/h	57
Steam consumption (72.5 psiG) - Low pressure	Lb/h	68,7
Steam pressure - Low Pressure	barG	3 - 6
	psiG	43.5 - 91
Steam Inlet - Steam Outlet - Low Pressure	BSPT - ISO7.1	1"

VENTILATION			
Nominal air flow	m ³ /h	850	
	cfm	500.29	
Air outlet Ø	mm	200	
	inch	8	
Fan motor power	kW	0.25	
HEAT DISSIPATION			
Total max heat dissipation	kW	1.8	
	kW	6145.5	
Front pannel max heat dissipation	Btu/h	1.26	
	Btu/h	4301.8	
CONNECTIONS		ELECTRICAL	GAS
Voltage 120/60/1~ + G	N° x AWG / A	-	3 X 12 /20 A
Voltage 230V/3~ + G	-	-	-
Voltage 480V/3 ~ + G	-	-	-
DIMENSIONS / PACKING DIMENSIONS			
Net width / Gross width	mm	785 / 865	
	inch	30.91 / 34.06	
Net depth / Gross depth	mm	1125 / 1210	
	inch	44.29 / 47.64	
Net height / Gross height	mm	1694 / 1840	
	inch	66.69 / 72.44	
Net weight / Gross weight	Kg	187 / 200	
	Lb	412.26 / 440.92	
OTHERS			
Sound level	dB	64	

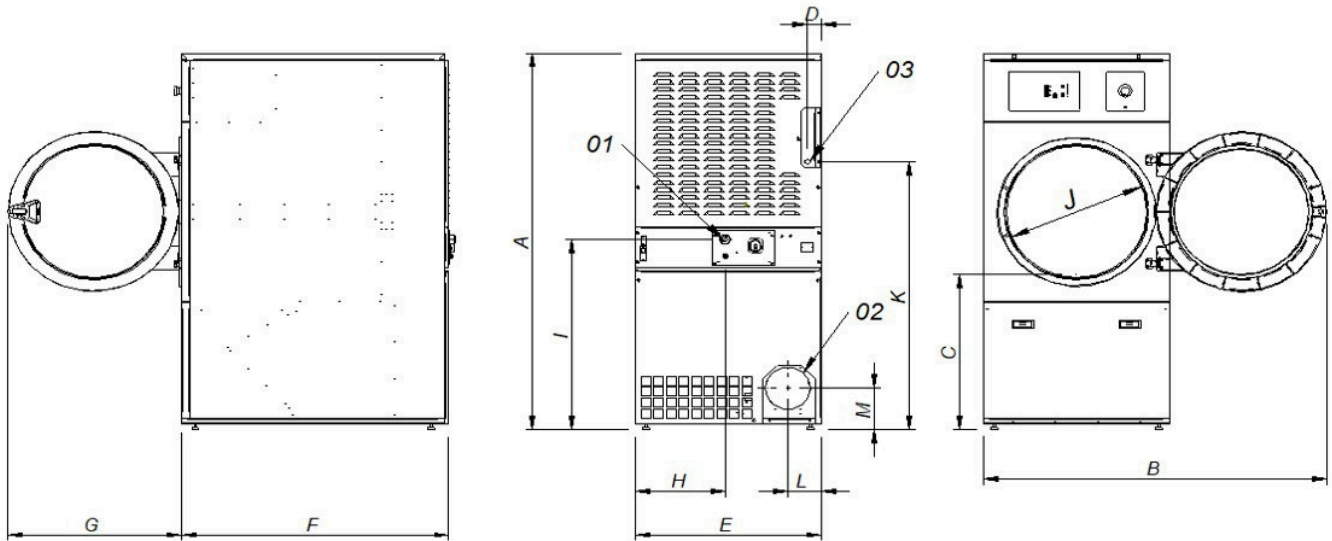

- 01. Power supply
- 02. Fumes output 8"
- 03. Gas inlet 1/2"

	A	B	C	D	E	F	G	H	I	J	K	L	M	N	O
FED-35 MG	66.69	56.96	27.12	2.67	30.90	44.29	28.93	14.96	34.25	22.63	48.26	5.23	7.08	1.37	31.69