



DRYING

SINGLE POCKET DRYERS ADVANCE FD-80 TP2



CHARACTERISTICS

TP2

- 7" touchscreen, user friendly and totally programmable.
- Videos on display, ads, instructions.
- Free software for programming, telemetry, data analysis.
- USB Connection.
- 37 Languages.
- 8 dosing signals.

OUTSTANDING FEATURES

- Reversing drum action is standard.
- Galvanized drum is standard.
- Frequency inverter is standard.

EFFICIENCY

- Large Lint filter.
- Optimized system of mixed airflow.

VERSATILITY

- Make to order - customization.
- Wet Cleaning configuration.
- OPL > OPL - Standard OPL model easily transformable to coin laundry uses.

CONNECTIVITY

- Standard IoT FagorKonnnect.
- Management of laundries: OPL and COIN.

ERGONOMICS

- Lint Filter Drawer, stainless steel mesh.
- Large Loading doors.

MAINTENANCE

- Hinged panel: easy and ergonomic access.
- Technical menu: statistics for technicians.

OTHERS

- Grey skin plate outer casing, stainless steel look.
- Drum with stamped holes.
- Anti-wrinkle at the end of the cycle.
- Heating options: natural gas and propane.
- CE approved.

OPTIONS

- Humidity sensor.
- Double door glass.
- Fire Extinguishing System.
- Opposite door opening.
- Tropicalized model.
- Dosing/spraying system.
- Back panel external air + filter.
- Fluff filter with grid 0.02 In (standard is 0.01 In).
- Fluff filter with grid 0.04 In (standard is 0.01 In).
- Stainless steel front and side panels.
- Front panel in stainless steel
- Other voltages available.

CAPACITY		
	U.	FD-80 TP2
Capacity 1/18	Kg	36.7
	Lb	80.8
Capacity 1/20	Kg	33
	Lb	72.8
DRUM		
Ø Drum	mm	947
	inch	37.28
Drum length	mm	936
	inch	36.85
Drum volume	l cu	660
	ft	23.3
Ø Door	mm	802
	inch	31.57
Floor to door center	mm	1040
	inch	40.94
Floor to lower part of the door	mm	578
	inch	22.74
Drum motor power	kW	0.55
ELECTRIC POWER		
Installed heating power	kW	36
Installed electrical power	kW	37.15
Evaporation capacity	l/h	31.1
	USgallon/h	8.2
Hourly output	Kg/h	60
	Lb/h	132.3
GAS POWER		
Installed heating power gas	Kcal/h	35276
	Btu/h	139986.5
Installed heating power gas	kW	41
Installed electrical power	kW	1.15
Instant propane gas consumption (G31)	Kg/h	3.51
	Lb/h	7.74
Instant natural gas consumption (G20)	m³/h	4.34
	cfm	2.55
Evaporation capacity	l/h	32.1
	USgallon/h	8.480
Hourly output Ø Gas inlet	Kg/h	63.9
	Lb/h	140.9
	BSPP ISO 228-1	1/2"
STEAM POWER		
Installed heating power steam	kW	50.1
	Btu/h	170948
Installed electrical power	kW	1.15
Steam consumption (8 barG) - Stándar	Kg/h	89
Steam consumption (116 psiG)	Lb/h	107.2
Steam pressure - Standard	barG	6 - 9
	psiG	87 - 130.5
Steam inlet - steam outlet - Standard	BSPT- ISO7.1	1"
Steam inlet - condensate outlet	NPT ANSI B1.20.1 Tapered	1"
Steam consumption (5 bagG) - Low pressure	Kg/h	93
Steam consumption (72,5 psiG) - Low pressure	Lb/h	112
Steam pressure - Low Pressure	barG	3 - 6
	psiG	43.5 - 97
Steam Inlet - Steam Outlet - Low Pressure	BSPT - ISO7.1	1 1/2"

VENTILATION			
Nominal air flow	m ³ /h	1200	
	cfm	706.29	
Air outlet Ø	mm	200	
	inch	7.87	
Fan motor power	kW	0.55	
HEAT DISSIPATION			
Total max heat dissipation	kW	3.6	
	kW	12290.9	
Front pannel max heat dissipation	Btu/h	2.52	
	Btu/h	8603.6	
CONNECTIONS		ELECTRICAL	GAS
Voltage 120/60/1~ + G	N° x AWG / A	-	3 X 12 /20 A
Voltage 230V/3~ + G	-	-	-
Voltage 480V/3 ~ + G	-	-	-
DIMENSIONS / PACKING DIMENSIONS			
Net width / Gross width	mm	985 / 1065	
	inch	38.78 / 41.93	
Net depth / Gross depth	mm	1210 / 1310	
	inch	47.64 / 51.57	
Net height / Gross height	mm	1975 / 2080	
	inch	77.76 / 81.89	
Net weight / Gross weight	Kg	260 / 285	
	Lb	573.20 / 628.32	
OTHERS			
Sound level	dB	65	

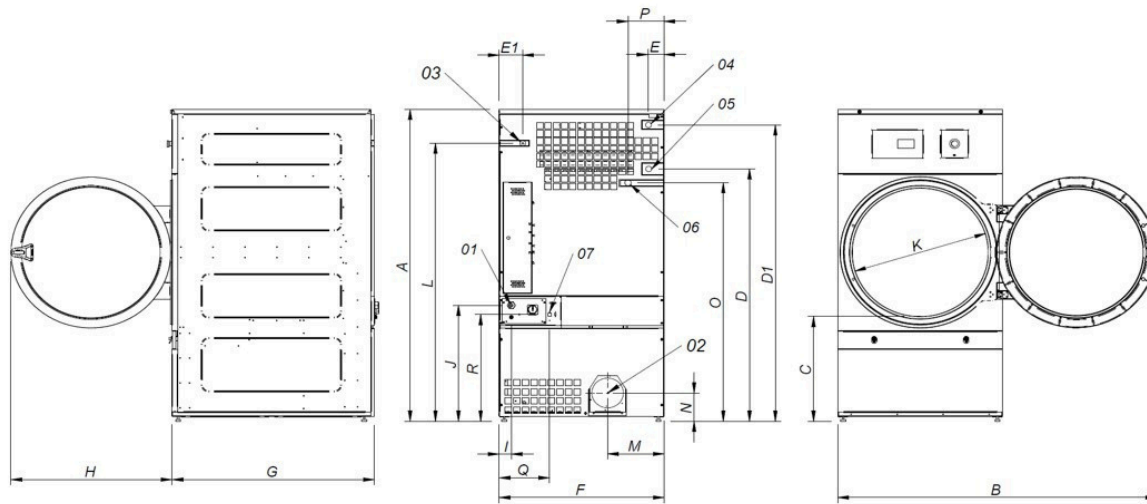

- 01. Power supply
- 02. Fumes output Ø200
- 03. Gas inlet 1/2"
- 04. Steam inlet 1"
- 05. Condensate outlet 1"
- 06. Sprinkler valve 3/4"
- 07. Ethernet connection

	A	B	C	D	D1	E	E1	F	G	H	I	J	K	L	M	N	O	P	Q	R
FD-80 TP2	77.75	75.19	25.98	62.59	73.81	4.01	5.11	38.77	47.63	38.18	2.75	28.74	31.57	69.29	13.26	7.00	59.44	8.46	11.85	26.61