



DRYING

SINGLE POCKET DRYERS ADVANCE FD-100 TP2



CHARACTERISTICS

TP2

- 7" touchscreen, user friendly and totally programmable.
- Videos on display, ads, instructions.
- Free software for programming, telemetry, data analysis.
- USB Connection.
- 37 Languages.
- 8 dosing signals.

OUTSTANDING FEATURES

- Reversing drum action is standard.
- Galvanized drum is standard.
- Frequency inverter is standard.

EFFICIENCY

- Large Lint filter.
- Optimized system of mixed airflow.

VERSATILITY

- Make to order - customization.
- Wet Cleaning configuration.

CONNECTIVITY

- Standard IoT FagorKonnnect.
- Management of laundries: OPL and COIN.

ERGONOMICS

- Lint Filter Drawer, stainless steel mesh.
- Large Loading doors.

MAINTENANCE

- Hinged panel: easy and ergonomic access.
- Technical menu: statistics for technicians.

OTHERS

- Grey skin plate outer casing, stainless steel look.
- **New:** transmission by geared motor on models FD-100/135/180.
- Drum with stamped holes.
- Anti-wrinkle at the end of the cycle.
- Heating options: natural gas and propane
- CE approved.

OPTIONS

- Automatic (double glass) or manual guillotine door.
- Humidity sensor.
- Fire Extinguishing System.
- Opposite door opening.
- Tropicalized model.
- Dosing/spraying system.
- Back panel external air + filter.
- Lint filter with grid 0.02 In (standard is 0.01 In).
- Lint filter with grid 0.04 In (standard is 0.01 In).
- Stainless steel front and side panels.
- Front panel in stainless steel.

CAPACITY		U.	FD-100 TP2
Capacity 1/18		Kg	50
		Lb	110.2
Capacity 1/20		Kg	45
		Lb	99.2
DRUM			
Ø Drum		mm	1225
		inch	48.23
Drum length		mm	760
		inch	29.92
Drum volume		l cu	900
		ft	31.78
Ø Door		mm	802
		inch	31.57
Floor to door center		mm	1275
		inch	50.20
Floor to lower part of the door		mm	813
		inch	31.99
Drum motor power		kW	0.75
ELECTRIC POWER			
Installed heating power		kW	54
Installed electrical power		kW	55.9
Evaporation capacity		l/h	40.2
		USgallon/h	10.6
Hourly output		Kg/h	80.4
		Lb/h	177.2
GAS POWER			
Installed heating power gas		Kcal/h	51591
		Btu/h	204728.5
Installed heating power gas		kW	60
Installed electrical power		kW	1.9
Instant propane gas consumption (G31)		Kg/h	5.14
		Lb/h	11.33
Instant natural gas consumption (G20)		m³/h	6.35
		cfm	3.74
Evaporation capacity		l/h	42.5
		USgallon/h	11.227
Hourly output Ø Gas inlet		Kg/h	84.4
		Lb/h	186.1
		BSPP ISO 228-1	3/4"
STEAM POWER			
Installed heating power steam		kW	91
		Btu/h	310505
Installed electrical power		kW	1.9
Steam consumption (8 barG) - Stándar		Kg/h	121
Steam consumption (116 psiG)		Lb/h	145.8
Steam pressure - Standard		barG	7 - 12
		psiG	101.5 - 174
Steam inlet - steam outlet - Standard		BSPT - ISO7.1	1"
Steam inlet - condensate outlet		NPT ANSI B1.20.1 Tapered	1"
Steam consumption (5 bagG) - Low pressure		Kg/h	142
Steam consumption (72,5 psiG) - Low pressure		Lb/h	171.1
Steam pressure - Low Pressure		barG	4 - 7
		psiG	58 - 101.5
Steam Inlet - Steam Outlet - Low Pressure		BSPT - ISO7.1	1" 1/2

THERMAL OIL			
Installed heating power	kW	91	
Installed electrical power	kW	1.9	
Fluid consumption (T max175°C)	m³/h	7	
Connections thermal oil	BSP	1" 1/2	
VENTILATION			
Nominal air flow	m³/h	3000	
	cfm	1765.73	
Air outlet Ø	mm	300	
	inch	11.81	
Fan motor power	kW	1.1	
HEAT DISSIPATION			
Total max heat dissipation	kW	4.86	
	Btu/h	16592.7	
Front pannel max heat dissipation	kW	2.16	
	Btu/h	7374.5	
CONNECTIONS		ELECTRICAL	GAS
Voltage 208-240/60/1~ + G		-	-
Voltage 230V /3~ + G		N° x mm2 / A	4x12 / 20 A
Voltage 440-480V /3~ +G		N° x mm2 / A	4X14 / 15 A
DIMENSIONS / PACKING DIMENSIONS			
Net width / Gross width	mm	1270 / 1330	
	inch	50 / 52.36	
Net depth / Gross depth	mm	1106 / 1185	
	inch	43.54 / 46.65	
Net height / Gross height	mm	2380 / 2200	
	inch	93.70 / 86.61	
Net weight / Gross weight	Kg	395 / 430	
	Lb	870.83 / 947.99	
OTHERS			
Sound level	dB	67	

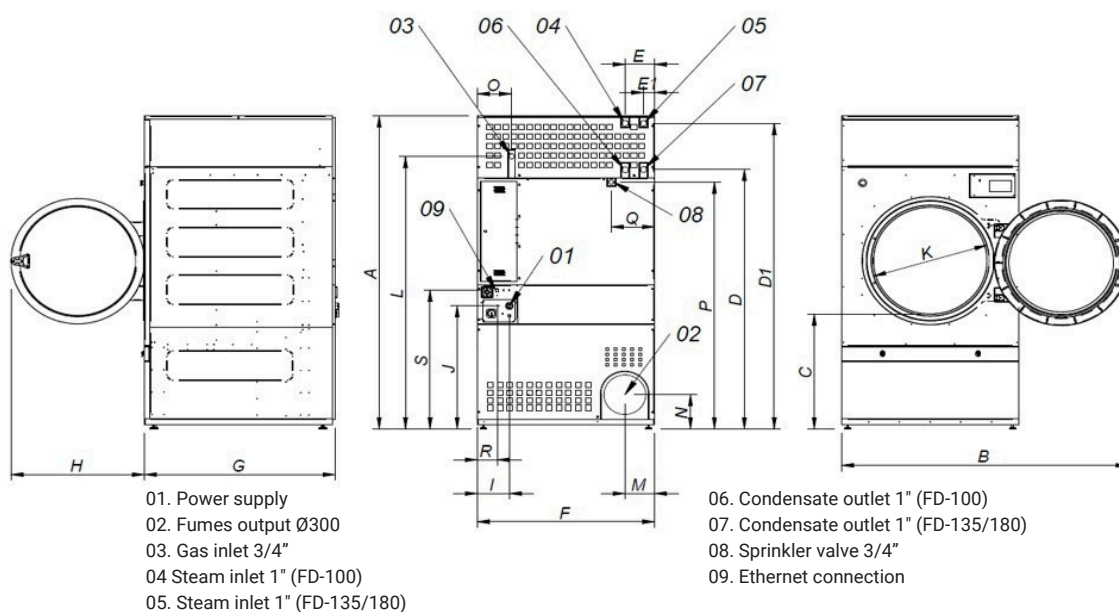

	A	B	C	D	D1	E	E1	F	G	H	I	J	K	L	M	N	O	P	Q	R	S
FD-100 TP2	93.70	80.51	34.40	77.99	90.98	8.30	3.14	50	43.54	37.63	9.76	36.81	31.57	82.20	8.4	9.44	9.60	72.48	12.12	6.29	41.45